

REVISIONS				
ZONE	REV	DESCRIPTION	DATE	APPROVED

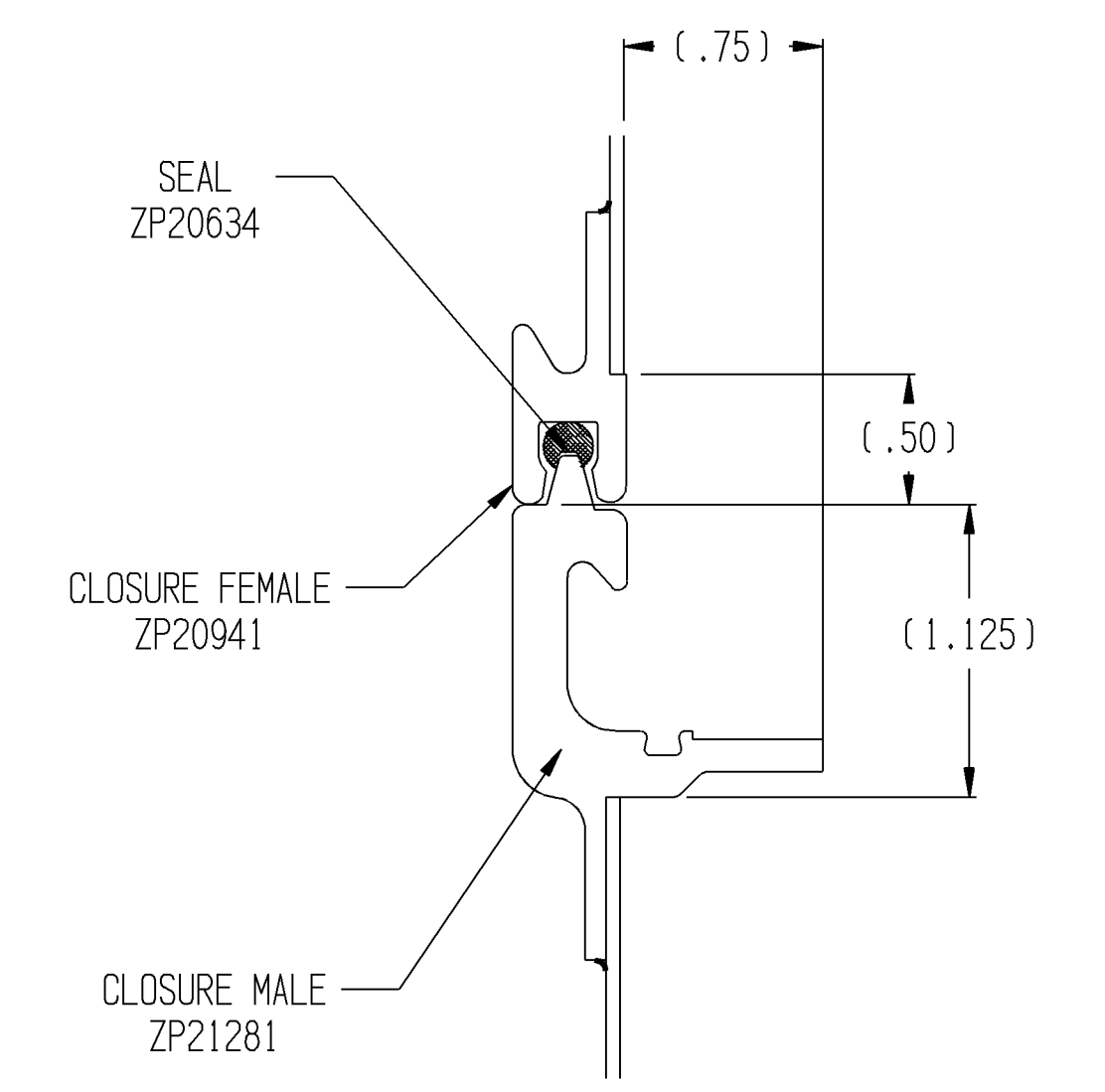

CLOSURE DETAIL

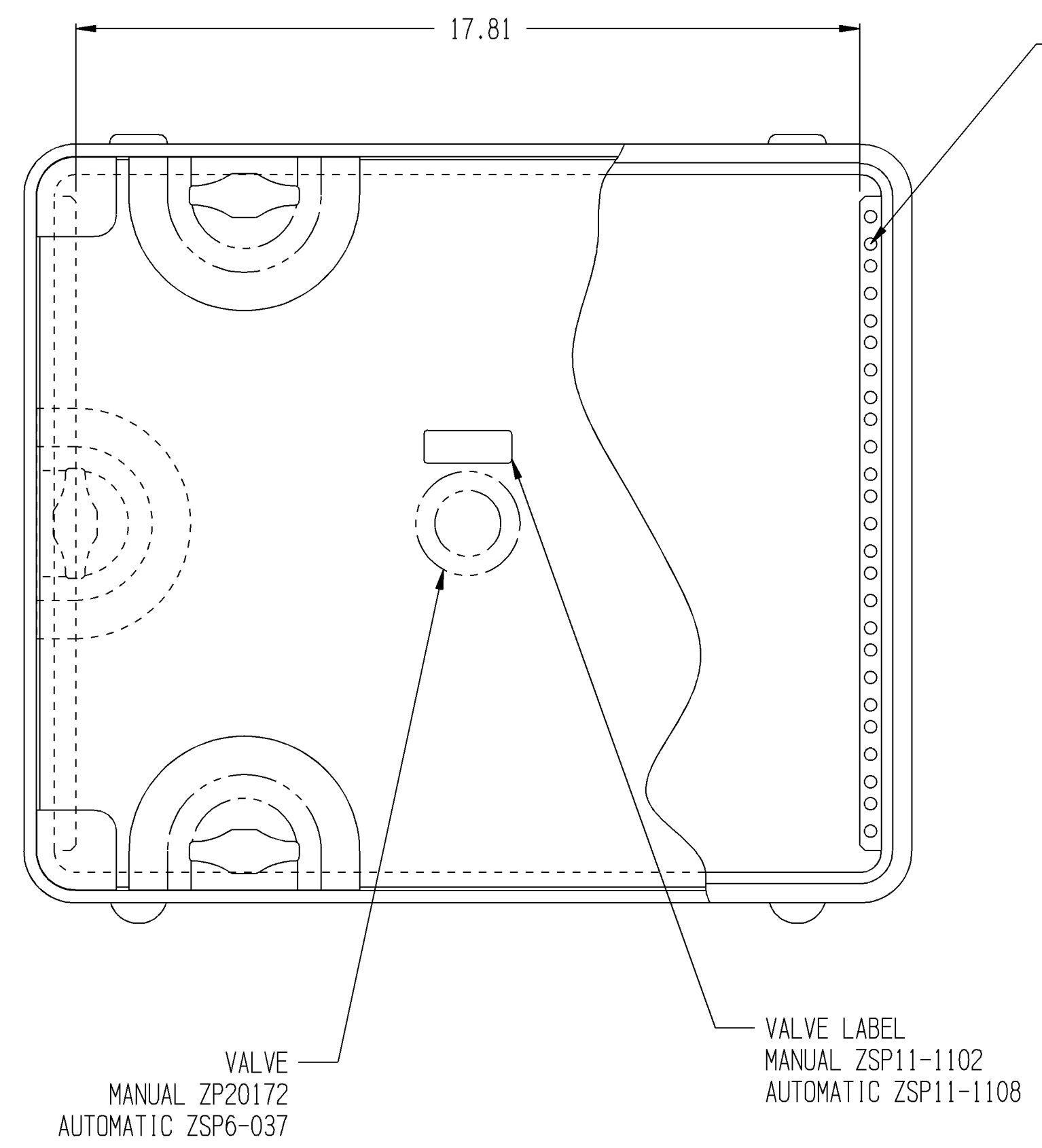
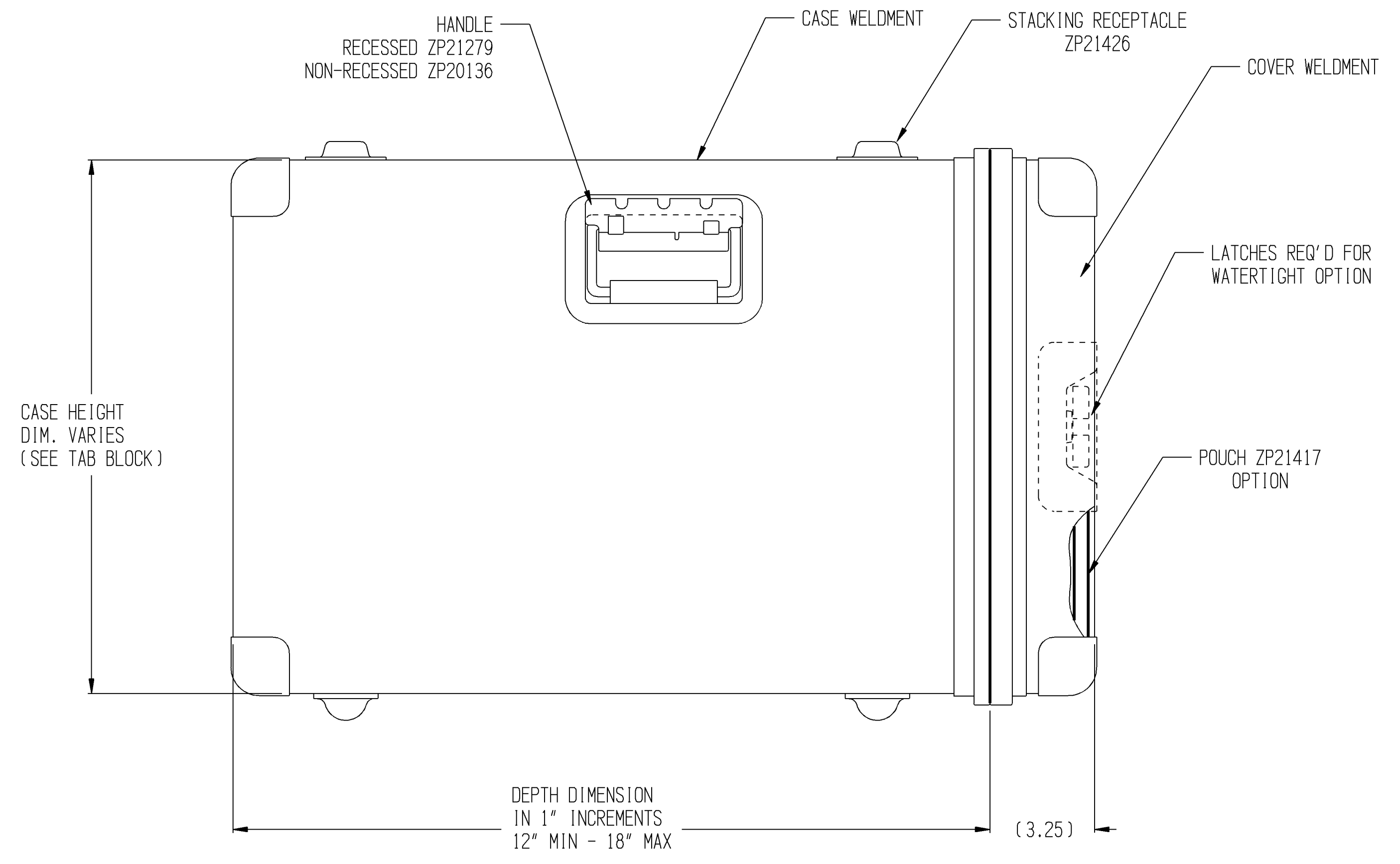
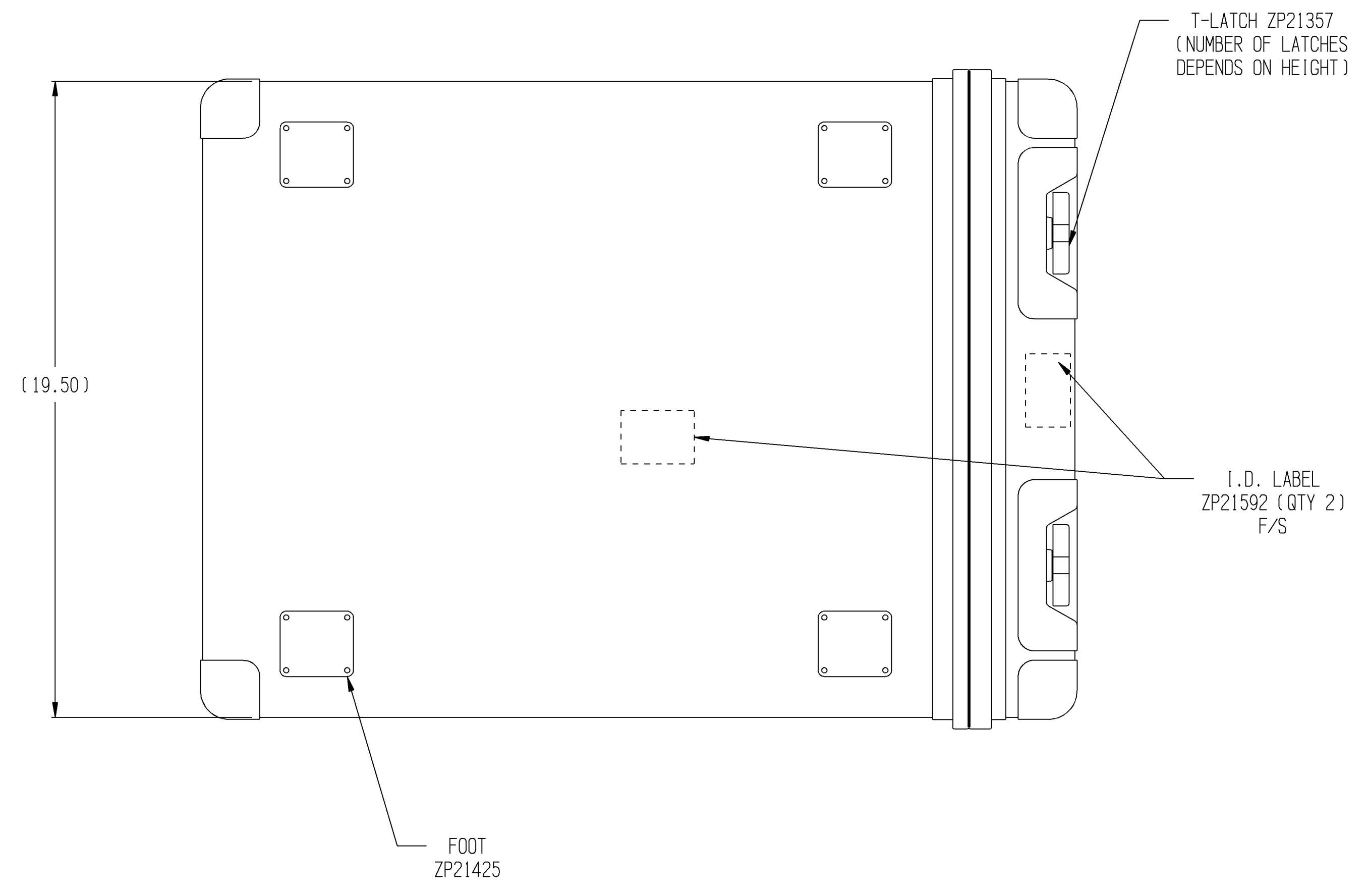

TABULATION BLOCK			
PANEL HEIGHT			
DASH NO.	DIM	REF.	CASE HT.
-	SPECIAL SIZE		
-7	7.00	(4U)	7.87
-8	8.75	(5U)	9.62
-10	10.50	(6U)	11.37
-14	14.00	(8U)	14.87
-17	17.50	(10U)	18.37
-21	21.00	(12U)	21.87
-24	24.50	(14U)	25.37
-28	28.00	(16U)	28.87

NOTES

1. WATERTIGHT PER MIL-STD-108, ZERO TEST NO. 1
DRIP PROOF PER MIL-STD-108, NO TEST REQUIRED.
2. CASES WITH PANEL HEIGHT 10U AND UNDER AND CENTER SECTION WITH
DEPTH UNDER 22.00" LONG, USE .063" THICK MATERIAL.
CASES WITH PANEL HEIGHT OVER 10U AND CENTER SECTION WITH
DEPTH OVER 22.00" LONG, USE .090" THICK MATERIAL.
3. CLIP NUT QUANTITY PER PANEL HEIGHT. SHIP LOOSE.
-7 QTY 10 -17 QTY 14
-8 QTY 14 -21 QTY 16
-10 QTY 14 -24 QTY 16
-14 QTY 14 -28 QTY 30
4. CASE TO BE UNLATCHED WHEN NO VALVE REQUIRED.
5. MAXIMUM EQUIPMENT WEIGHT 150 LBS
6. PROTECTION LEVELS: 30 G'S FROM 18" DROP HEIGHT.

This document and the drawings and the technical data contained hereon are the property of Zero Mfg. Inc., formerly APW Zero Cases, Zero Enclosures, and Zero Mfg. Co. Reproduction or dissemination in any form except as expressly authorized by the owner is forbidden. The holder agrees to return this document to the owner on demand.
Copyright by Zero Mfg. Inc.

UNLESS OTHERWISE SPECIFIED
DIMENSIONS ARE IN INCHES
TOLERANCES ARE:
FRACTIONS DECIMALS ANGLES
+ 1/32 .XX ±.03 ± 1/2°
 .XXX ±.010

DO NOT SCALE DRAWING

ZERO ZERO MANUFACTURING, INC.
North Salt Lake, UT 84054

CASE ASSEMBLY
VAL-AN SERIES 900

SIZE CASE NO. **D1 98376** DWG. NO. **905**

SCALE 1:3 SHEET 1 OF 1

DWG. NO. 905
SH 1 REV.