

REVISIONS				
ZONE	REV	DESCRIPTION	DATE	APPROVED

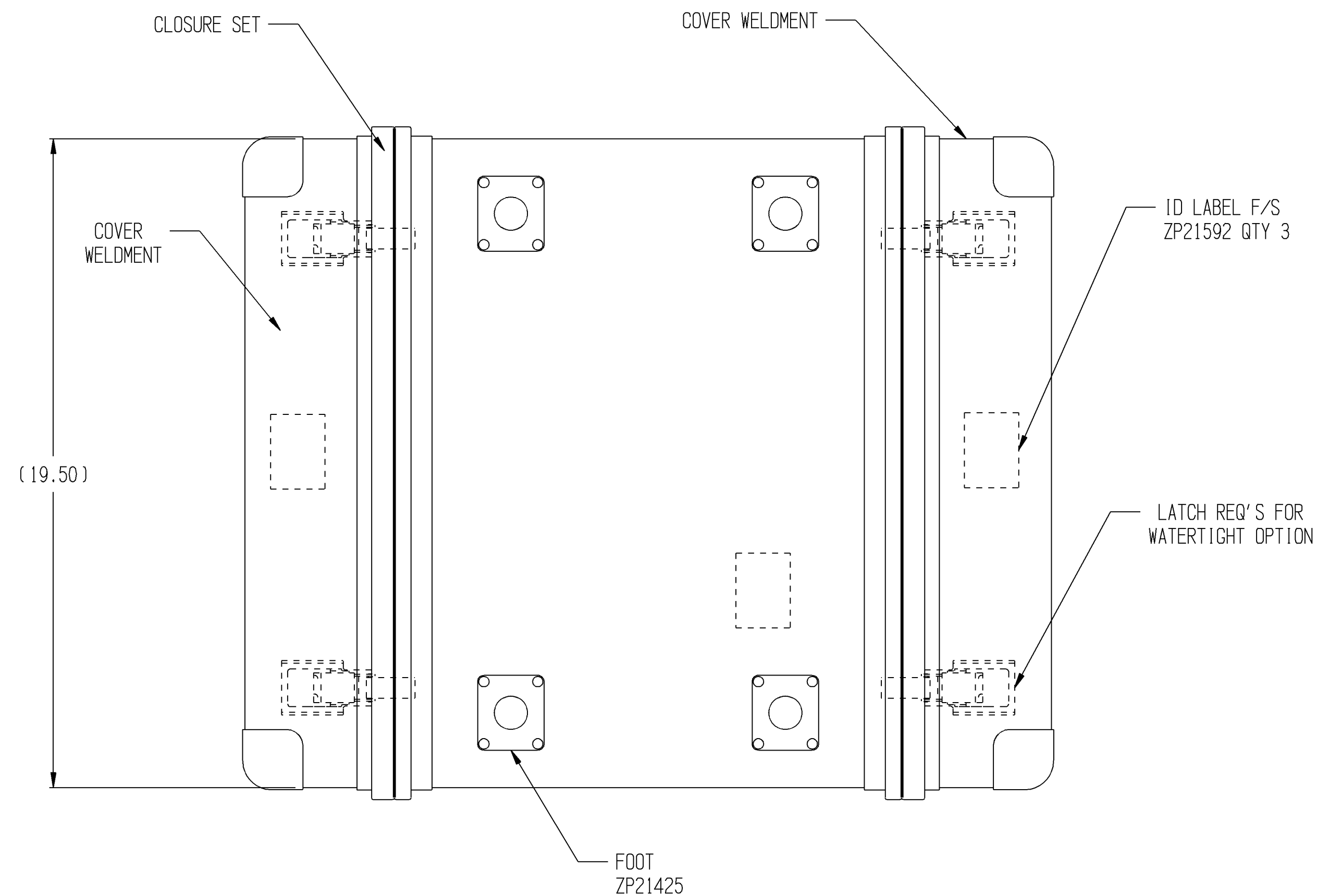
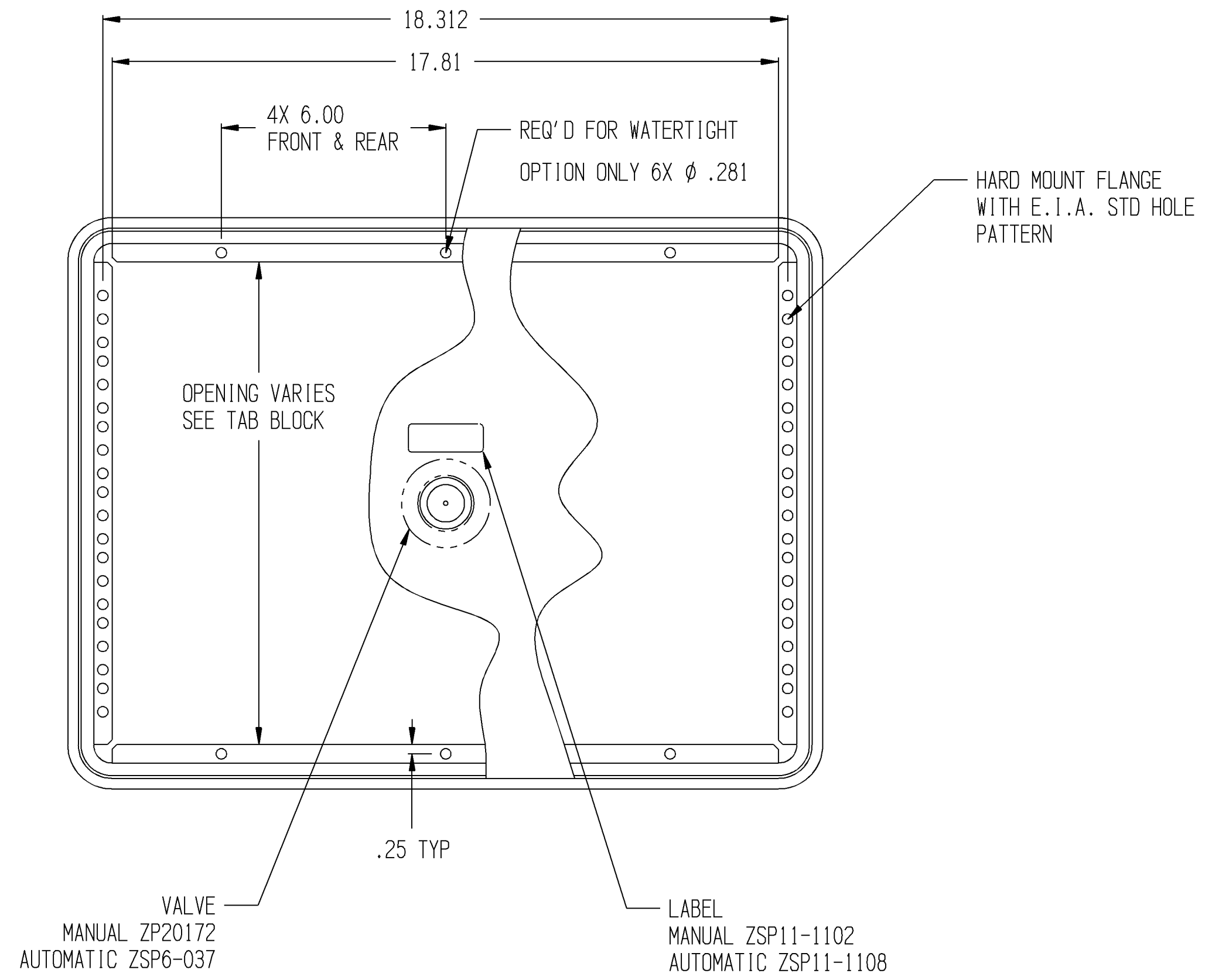
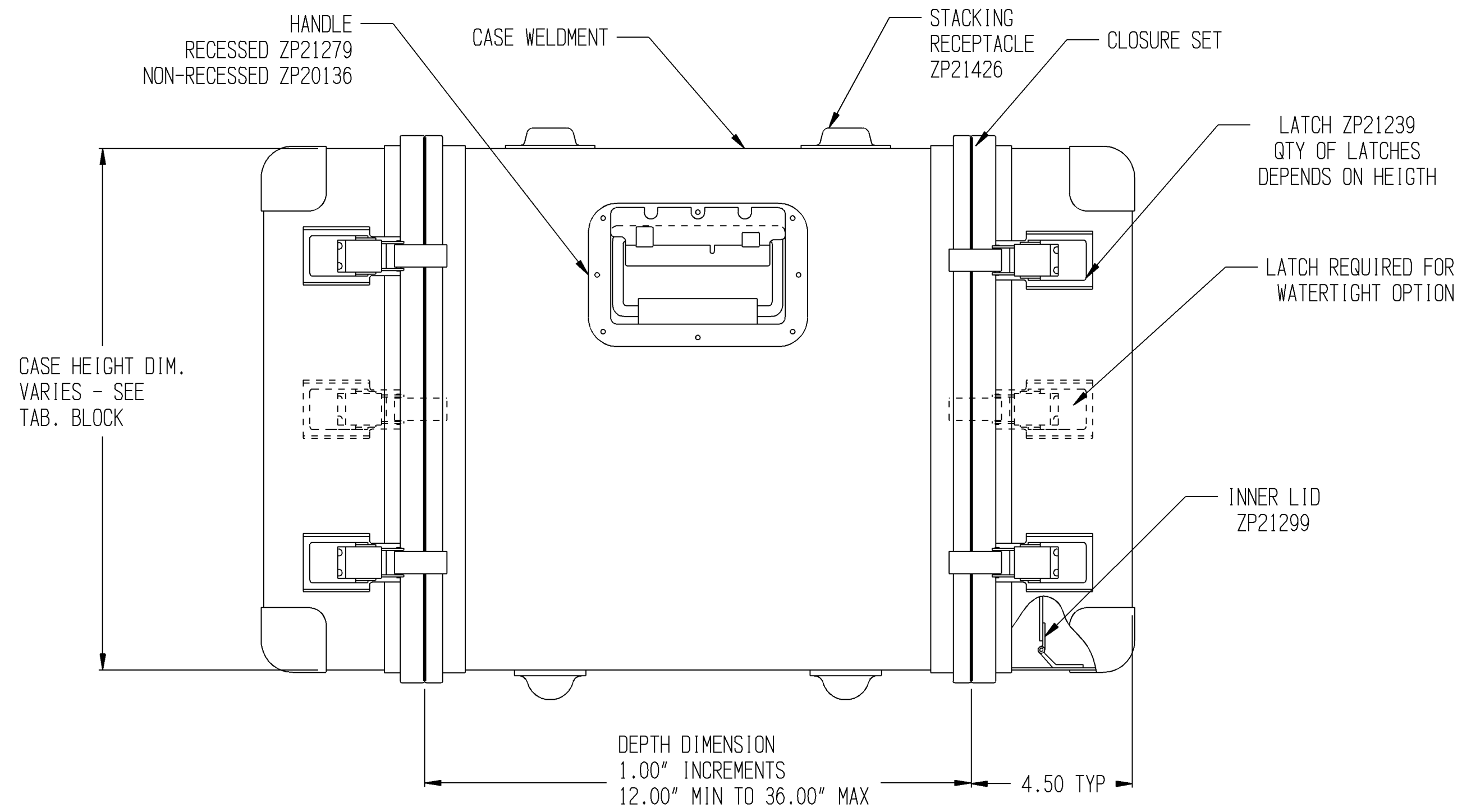

TABULATION BLOCK				
DASH NO.	PANEL HEIGHT		CASE HT.	FRAME OPENING
	DIM	REF.		(REF)
-	SPECIAL SIZE			
-5	5.25	(3U)	6.94	5.25
-7	7.00	(4U)	8.69	7.00
-8	8.75	(5U)	10.44	8.75
-10	10.50	(6U)	12.19	10.50
-14	14.00	(8U)	15.69	14.00
-17	17.50	(10U)	19.19	17.50
-21	21.00	(12U)	22.69	21.00
-24	24.50	(14U)	26.19	24.50
-28	28.00	(16U)	29.69	28.00

TAB BLOCK FOR
WATERTIGHT, DRIP PROOF
AND MIL-T-28800 STYLE A

VIEWS SHOWN FOR WATERTIGHT AND
DRIP PROOF OPTIONS

UNLESS OTHERWISE SPECIFIED
DIMENSIONS ARE IN INCHES
TOLERANCES ARE:
FRACTIONS DECIMALS ANGLES

This document and the drawings and the technical data contained hereon are the property of Zero Mfg. Inc., formerly APW Zero Cases, Zero Enclosures, and Zero Mfg. Co. Reproduction or dissemination in any form except as expressly authorized by the owner is forbidden. The holder agrees to return this document to the owner on demand.
Copyright by Zero Mfg. Inc.

ZERO ZERO MANUFACTURING, INC.
North Salt Lake, UT 84054

CASE ASSEMBLY
VAL-AN SERIES 900

SIZE CAGE NO. DWG. NO.
D 98376 930

DWG. NO. 930

A

REVISIONS				
ZONE	REV	DESCRIPTION	DATE	APPROVED

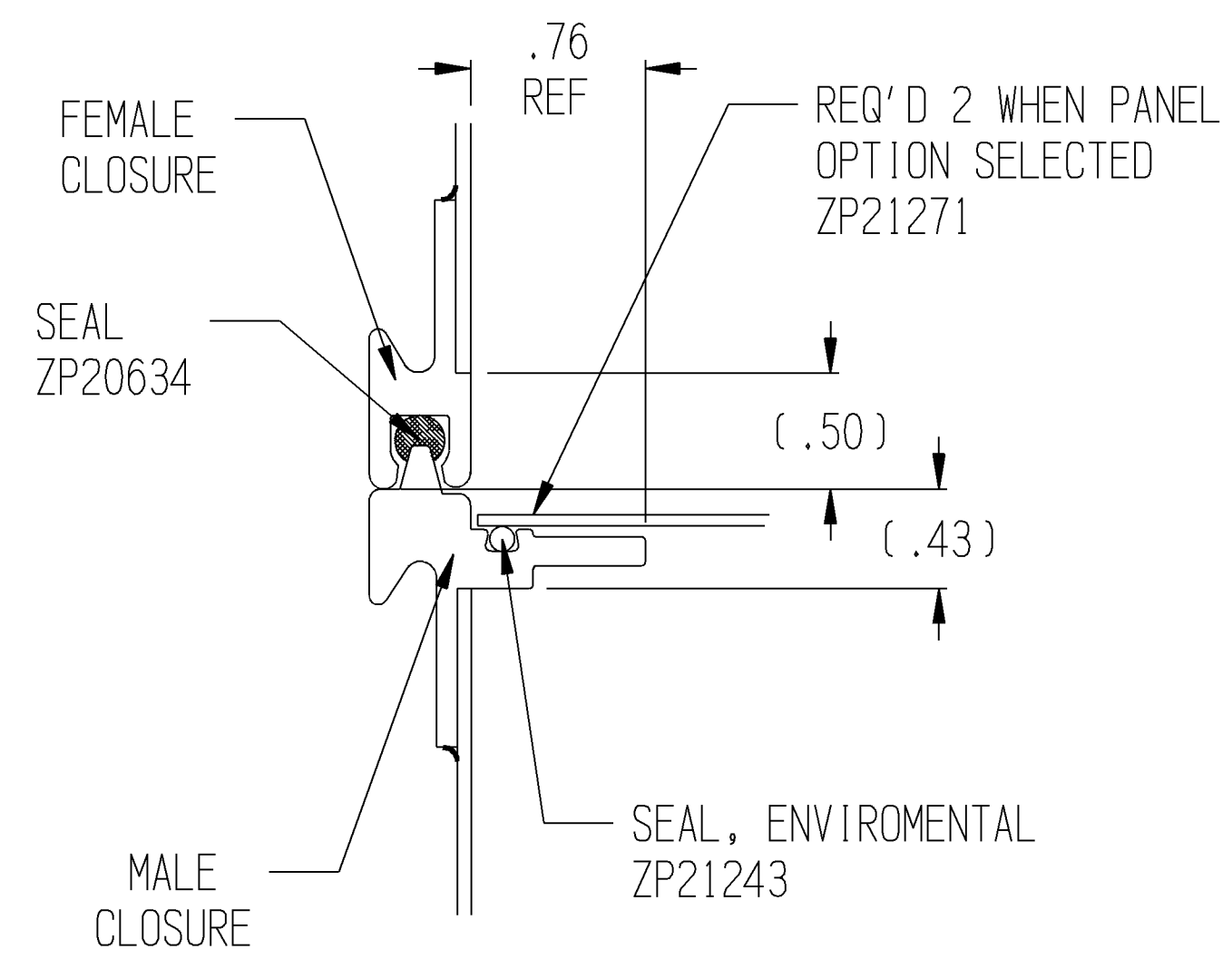
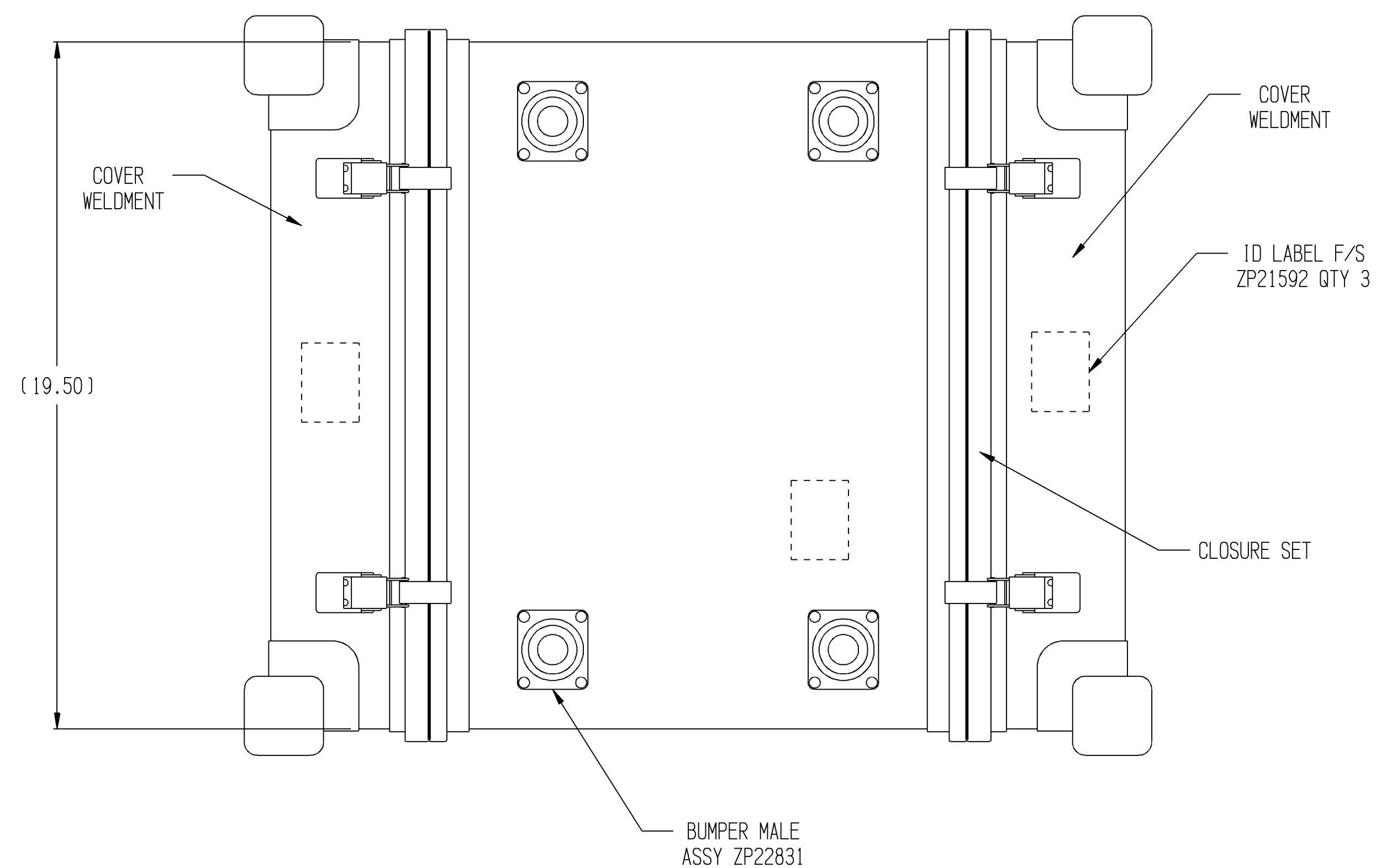
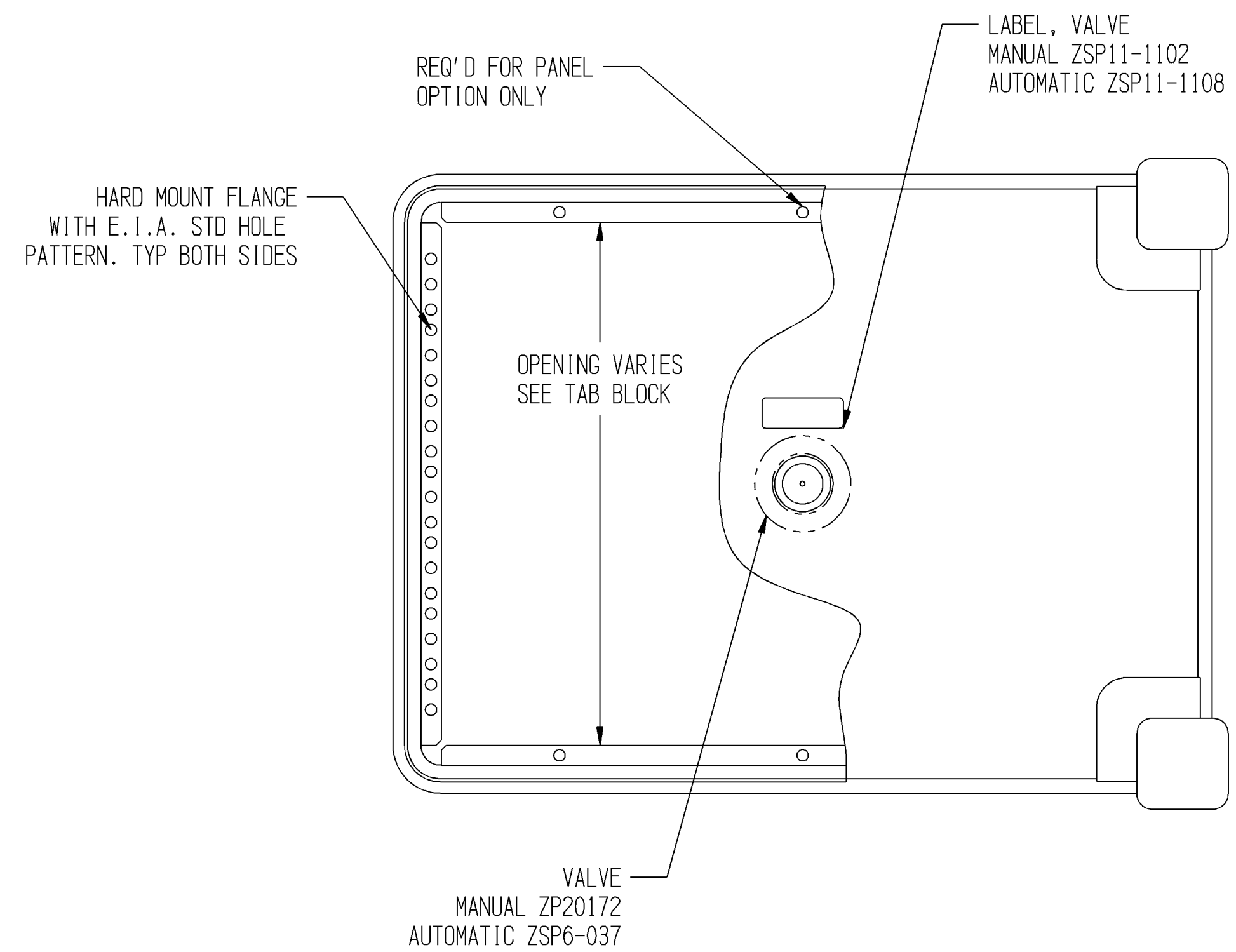
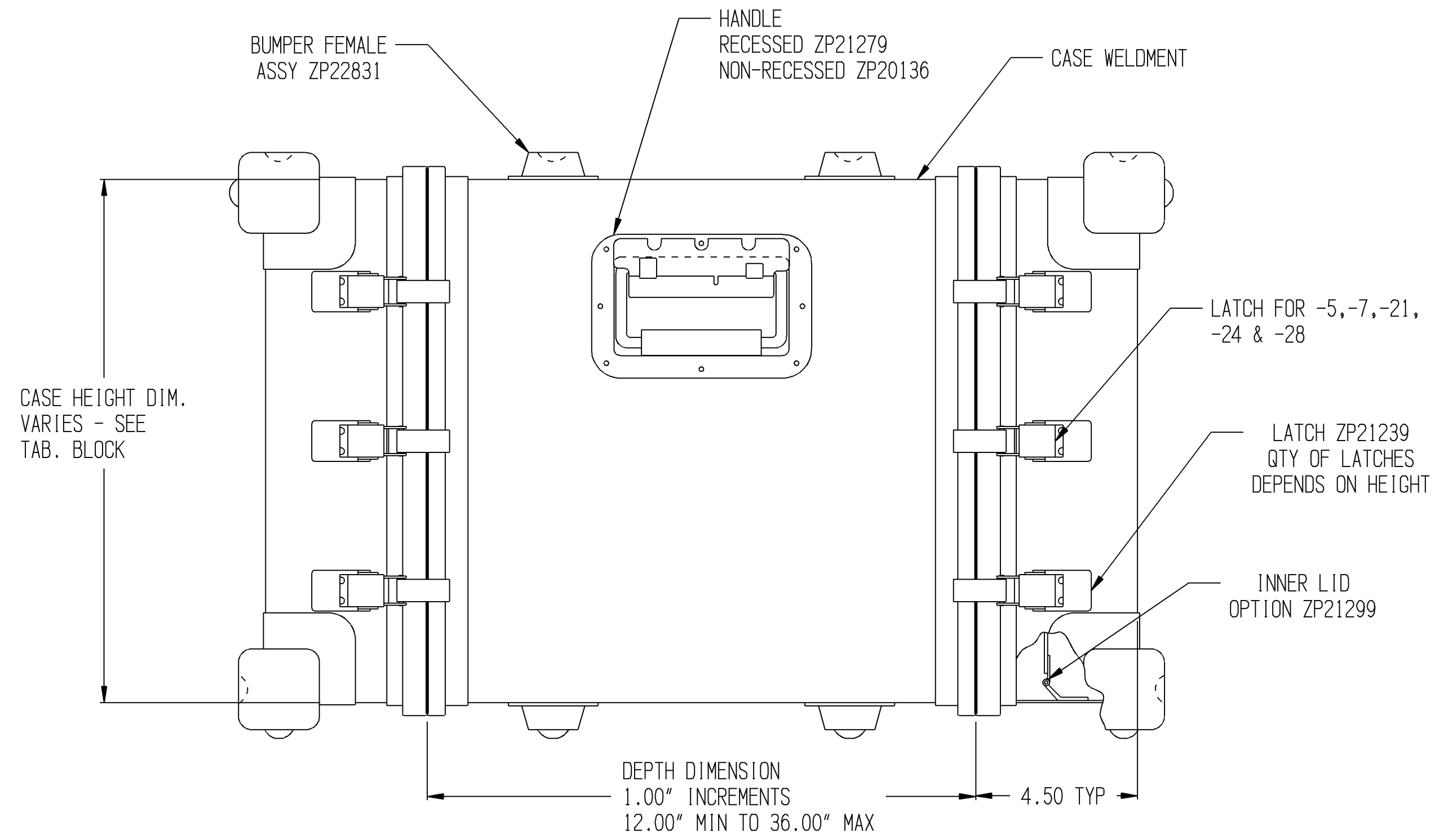

CLOSURE DETAIL
 FOR WATERTIGHT, DRIP PROOF AND MIL-T-28800 STYLE A

- NOTES:
1. WATERTIGHT PER MIL-STD-108, ZERO TEST NO. 1
DRIP PROOF PER MIL-STD-108, NO TEST REQUIRED.
 2. CASES WITH PANEL HEIGHT 10U AND UNDER AND CENTER SECTION WITH DEPTH UNDER 22.00" LONG, USE .063" THICK MATERIAL.
CASES WITH PANEL HEIGHT OVER 10U AND CENTER SECTION WITH DEPTH OVER 22.00" LONG, USE .090" THICK MATERIAL.
 3. CLIP NUT QUANTITY PER PANEL HEIGHT. SHIP LOOSE.

-5 QTY 20	-14 QTY 28	-28 QTY 44
-7 QTY 20	-17 QTY 28	
-8 QTY 28	-21 QTY 36	
-10 QTY 28	-24 QTY 36	
 4. SHIP CASE UNLATCHED WHEN NO VALVE REQUIRED.
 5. MAXIMUM EQUIPMENT WEIGHT 150 LBS.
 6. PROTECTION LEVELS: 30 G'S FROM 18.00" DROP HEIGHT.

VIEW FOR MIL-T-28800 STYLE "A" OPTION

This document and the drawings and the technical data contained hereon are the property of Zero Mfg. Inc., formerly APW Zero Cases, Zero Enclosures, and Zero Mfg. Co. Reproduction or dissemination in any form except as expressly authorized by the owner is forbidden. The holder agrees to return this document to the owner on demand.
 Copyright by Zero Mfg. Inc.

ZERO ZERO MANUFACTURING, INC.
 North Salt Lake, UT 84054

SIZE	CAGE NO.	DWG. NO.
D	98376	930
DO NOT SCALE DRAWING	FILE 930--revK-S2.ckd	SCALE 1:3 ZERO STD
SHEET		2 OF 2