

REVISIONS				
ZONE	REV	DESCRIPTION	DATE	APPROVED

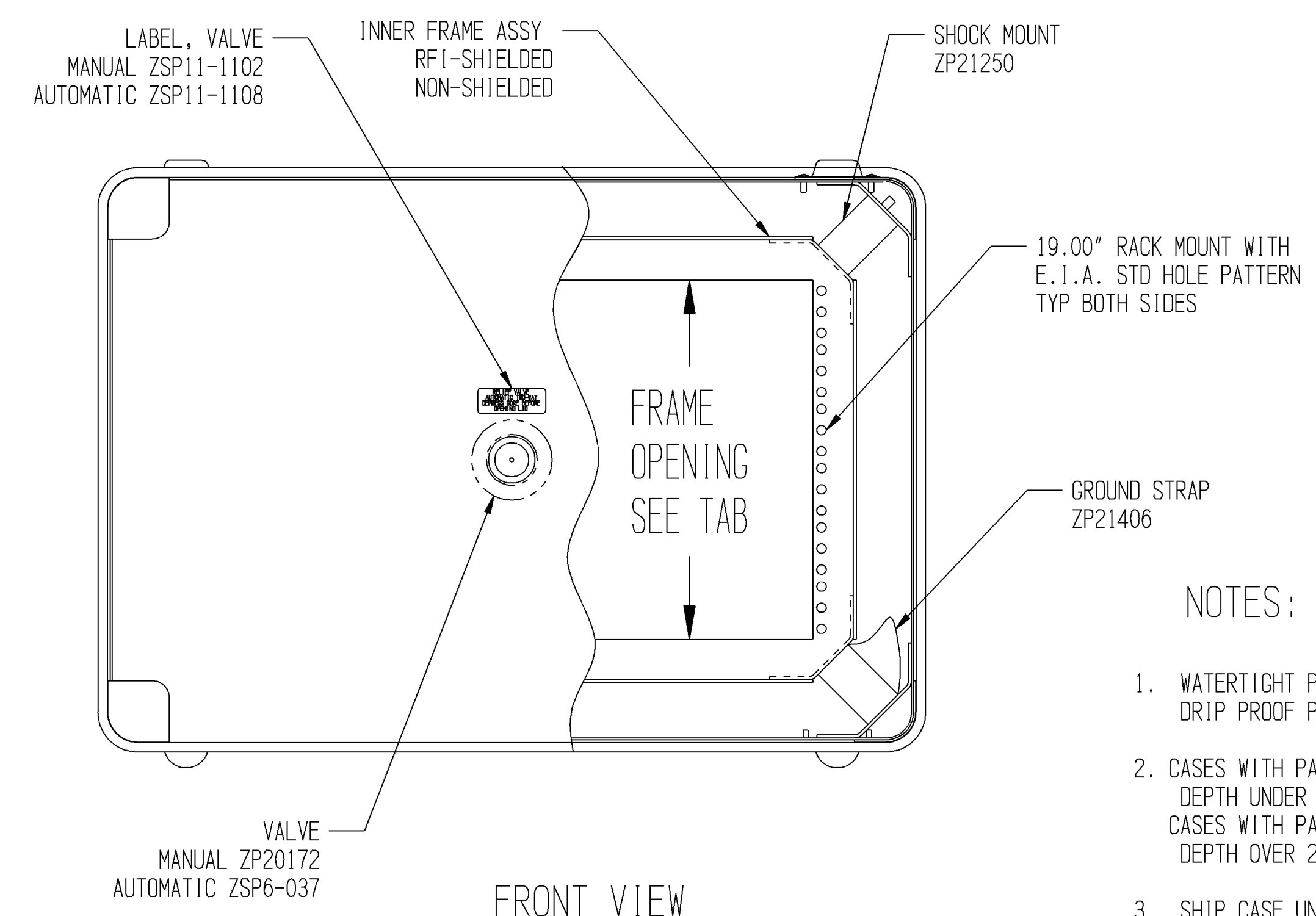

- NOTES:
1. WATERTIGHT PER MIL-STD-108, ZERO TEST NO. 1 DRIP PROOF PER MIL-STD 108, NO TEST REQUIRED.
  2. CASES WITH PANEL HEIGHT 10U AND UNDER AND CENTER SECTION WITH DEPTH UNDER 22.00" LONG, USE .063" THICK MATERIAL. CASES WITH PANEL HEIGHT OVER 10U AND CENTER SECTION WITH DEPTH OVER 22.00 LONG, USE .090" THICK MATERIAL.
  3. SHIP CASE UNLATCHED WHEN NO VALVE REQUIRED.
  4. MAXIMUM EQUIPMENT WEIGHT 150 LBS.
  5. PROTECTION LEVELS: 30 G'S FROM 18.00" DROP HEIGHT.

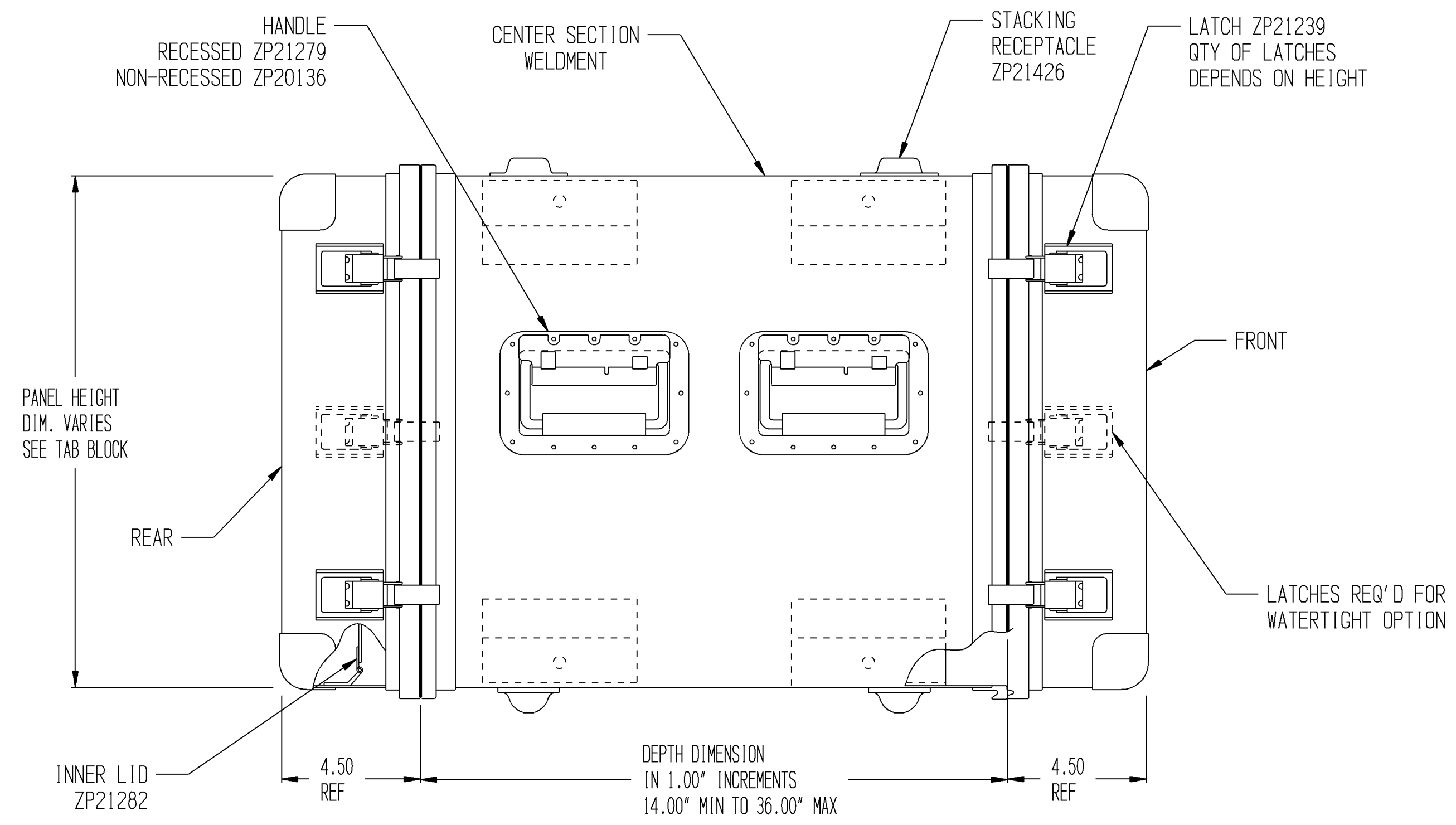
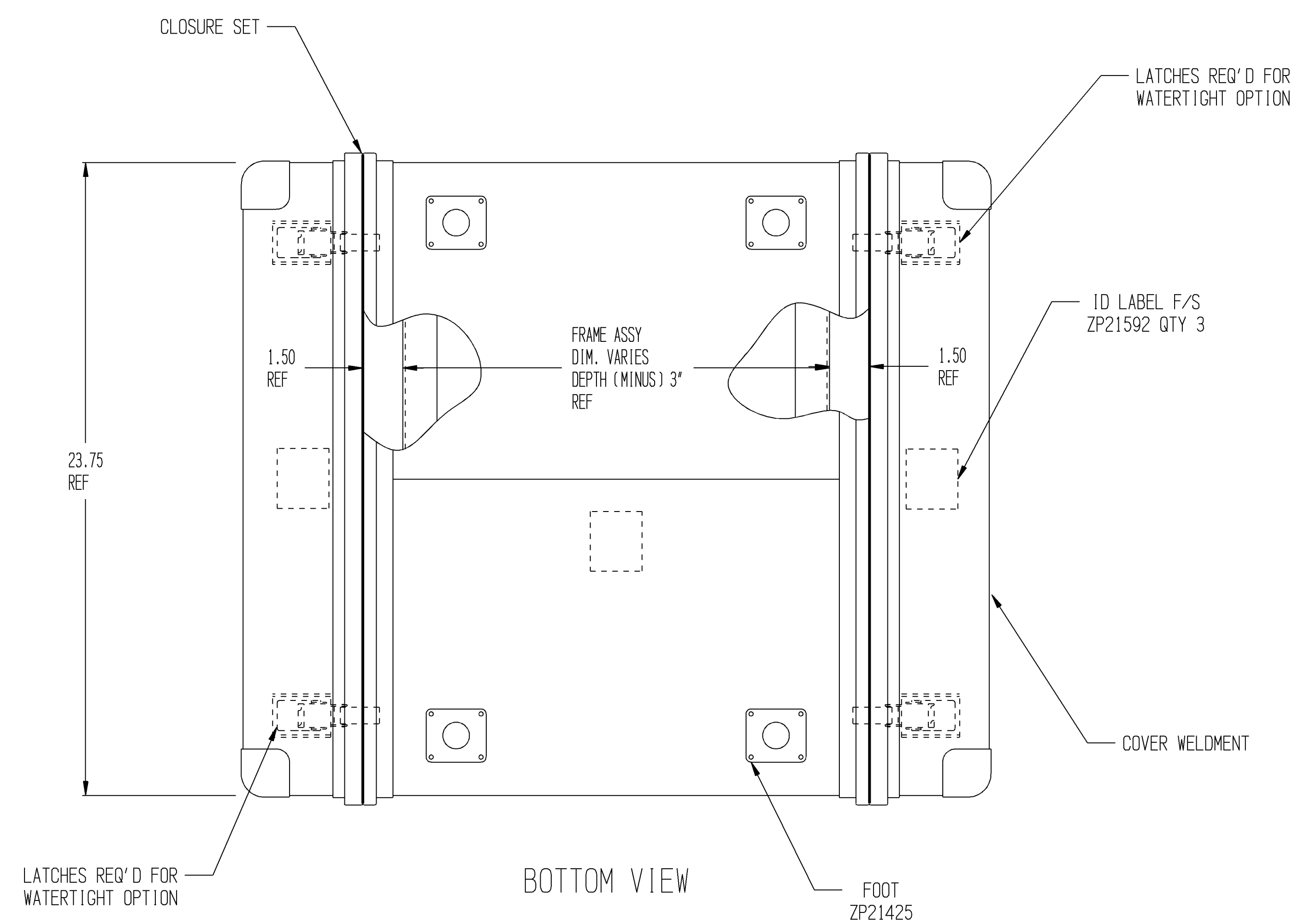

TABULATION BLOCK				
PANEL HEIGHT			CASE HEIGHT	FRAME OPENING REF
DASH NO	DIM	REF		
X	SPECIAL SIZE			
5	5.25	(3U)	11.31	5.37
7	7.00	(4U)	13.06	7.12
8	8.75	(5U)	14.81	8.87
10	10.50	(6U)	16.56	10.62
14	14.00	(8U)	20.06	14.12
17	17.50	(10U)	23.56	17.62
21	21.00	(12U)	27.06	21.12
24	24.50	(14U)	30.56	24.62
28	28.00	(16U)	34.06	28.12

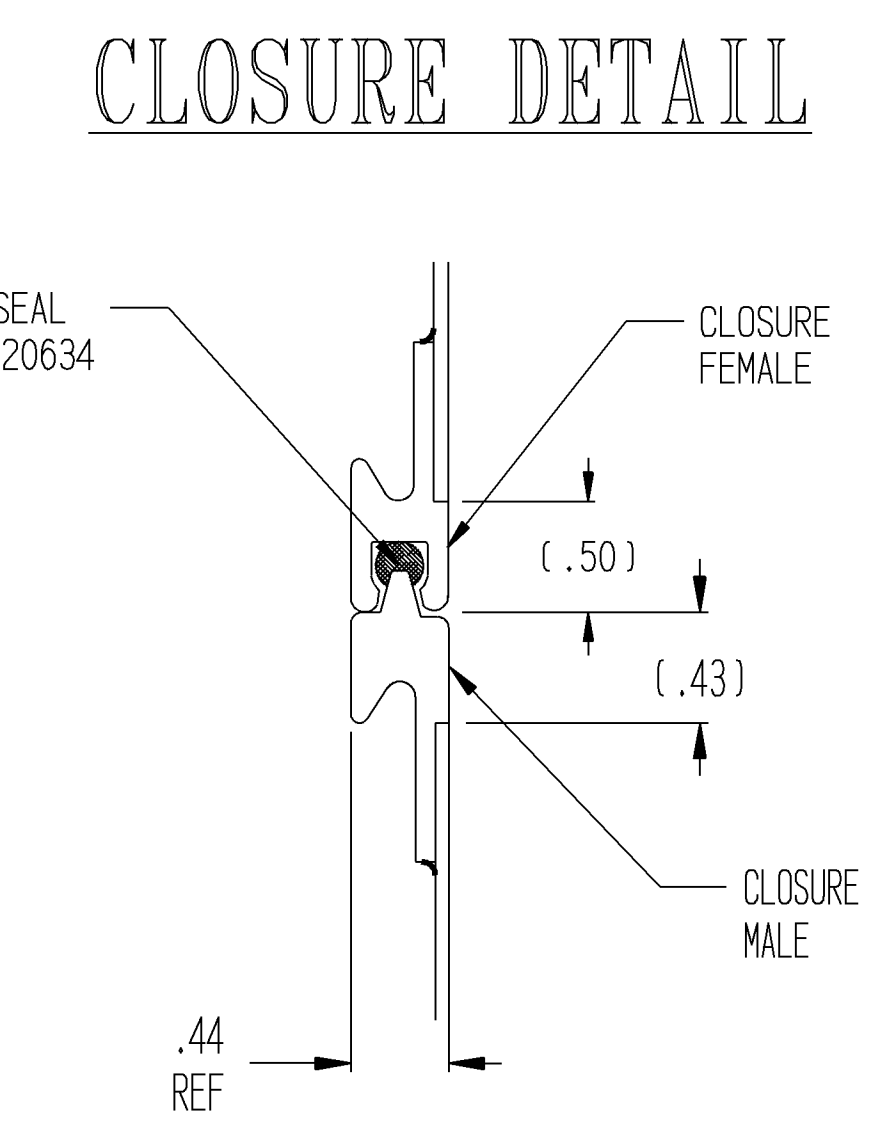

UNLESS OTHERWISE SPECIFIED DIMENSIONS ARE IN INCHES TOLERANCES ARE:

FRACTIONS	DECIMALS	ANGLES
± 1/32	.XX ±.03 .XXX ±.010	± 1/2°

Copyright by Zero Mfg. Inc.

**ZERO** ZERO MANUFACTURING, INC.  
North Salt Lake, UT 84054

CASE ASSEMBLY  
VAL-AN SERIES 900

SIZE CAGE NO. D 98376 DWG. NO. 950  
SCALE 1/3.5 ZERO STD SHEET 2 OF 2

DD NOT SCALE DRAWING FILE 950--revN.ckd

DWG. NO. 950 SH. 2